



CROWD CONTROL

STAGE BARRIERS



EVENT SAFETY MANAGEMENT

E office@noaevent.ro T + 40 728 303927 W www.crowdandsafety.ro

EVENT SAFETY MANAGEMENT

STAGE BARRIERS with Fingers Save System

Aluminum crowd barriers are lightweight but robust crowd control systems. Ideal solution to delimit or impede access to and from open spaces during sports events, political rallies, parades, demonstrations, and outdoor and indoor performances.



Strengths

Fingers Save System is the **strength** of Efesto's crowd barriers. This safety is given from combination of edges rounded and a special self-centering upper connection.

EVENT SAFETY MANAGEMENT

E office@noaevent.ro T + 40 728 303927 W www.crowdandsafety.ro

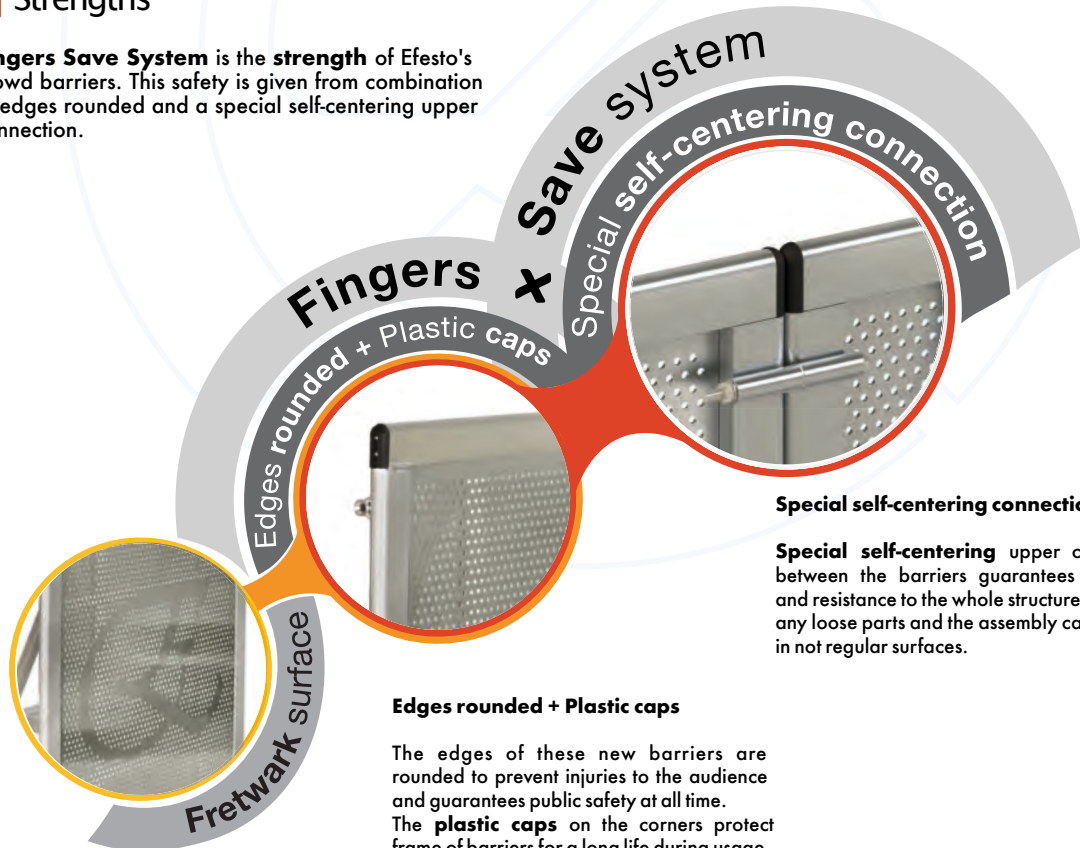

Special self-centering connection

Special self-centering upper connection between the barriers guarantees stability and resistance to the whole structure without any loose parts and the assembly can be set in not regular surfaces.

Edges rounded + Plastic caps

The edges of these new barriers are rounded to prevent injuries to the audience and guarantees public safety at all time. The **plastic caps** on the corners protect frame of barriers for a long life during usage.

Fretwork surface

Fretwork surface for a better lightweight, sound transmission and visibility.



STAGE BARRIERS STANDARD MODULE

Inventory - 200 pieces

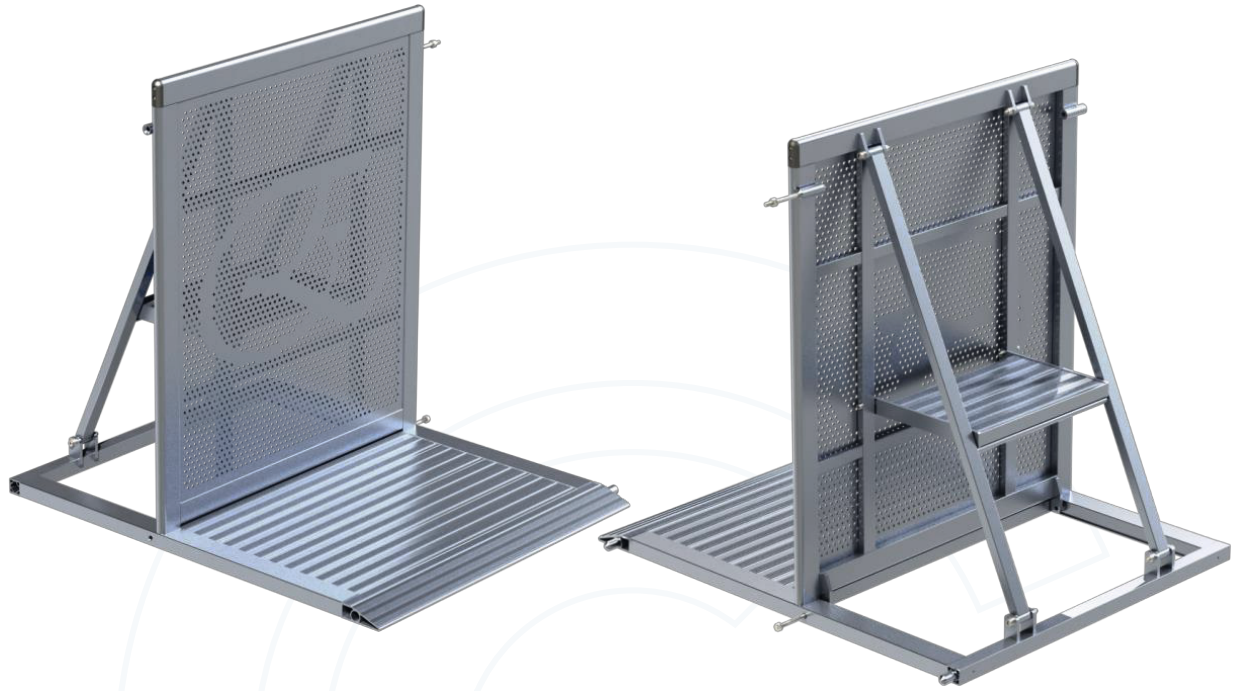

Standard module

The modules are bolted together for one firmly anchored fence.

Set up and assembly are fast and easy thanks connection kit: **only two bolts**.

The crowd barrier, on the back, has practical step that allows at security personnel the access to the public when it is need.

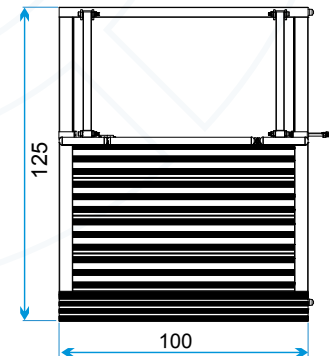
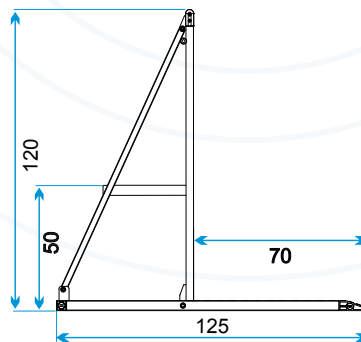
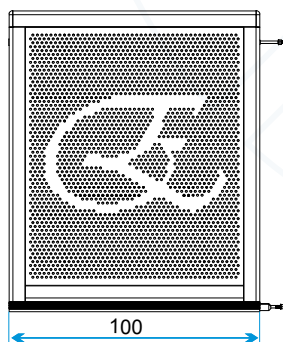

TECHNICAL DATA

Material	Aluminum alloy
Open Barrier dimensions	100 x 125 H 120 cm
Closed Barrier dimensions	100 x 125 H 10 cm
Step services dimensions	30 x 47 H 50 cm
Weight	38 kg

Advantages

- **Fingers Save System**
- Extended anti skid footboard for a better stable
- Safe and comfortable solutions for both the audience and rescue personnel.

STAGE BARRIERS ADJUSTABLE CORNER MODULE

Inventory - 12 pieces

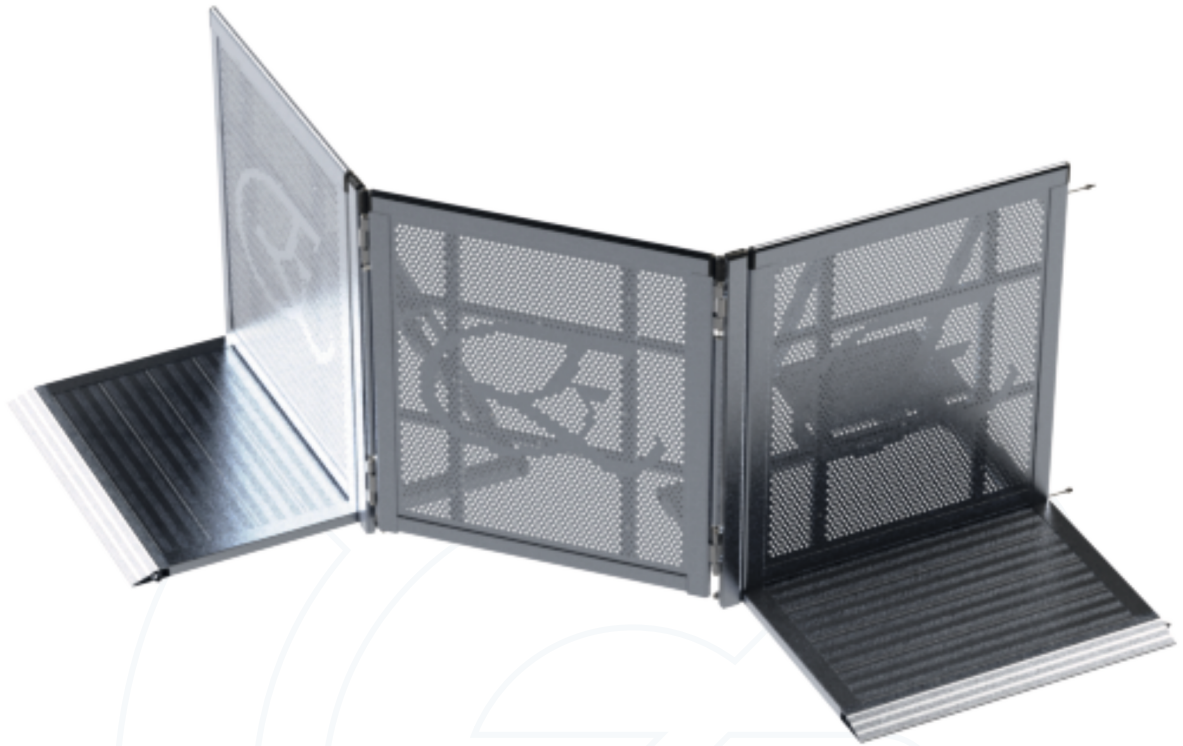

Adjustable corner module

Adjustable corner modules, made of aluminum, are available in several corner types for any need of applications. Adjustable corner module can vary from $\pm 90^\circ$.

The flexible corner is equipped with a robust heavy duty hinge and can be used as an inside as well as an outside corner. The **Adjustable corner modules** can be used also as regular barrier.

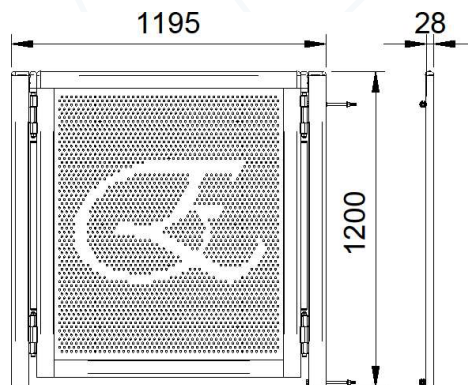

Range of use

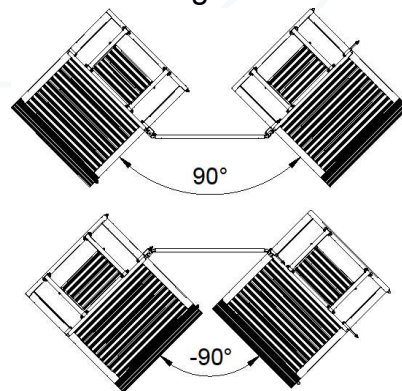

TECHNICAL DATA

Material	Aluminum alloy
Open Barrier dimensions	100 x 125 H 5 cm
Closed Barrier dimensions	100 x 125 H 5 cm
Corner	$+90^\circ$ or -90°
Weight	20 kg

Advantages

- **Fingers Save System**
- Safe and comfortable solutions for both the audience and rescue personnel.

STAGE BARRIERS ADJUSTABLE CORNER MODULE

Inventory - 8 pieces



Adjustable corner module

Adjustable corner modules, made of aluminum, are available in several corner types for any need of applications. Adjustable corner module can vary from $\pm 60^\circ$.

The flexible corner is equipped with a robust heavy duty hinge and can be used as an inside as well as an outside corner.

The **Adjustable corner modules** can be used also as regular barrier.

This safety is given from combination of edges rounded and a special self-centering upper connection.

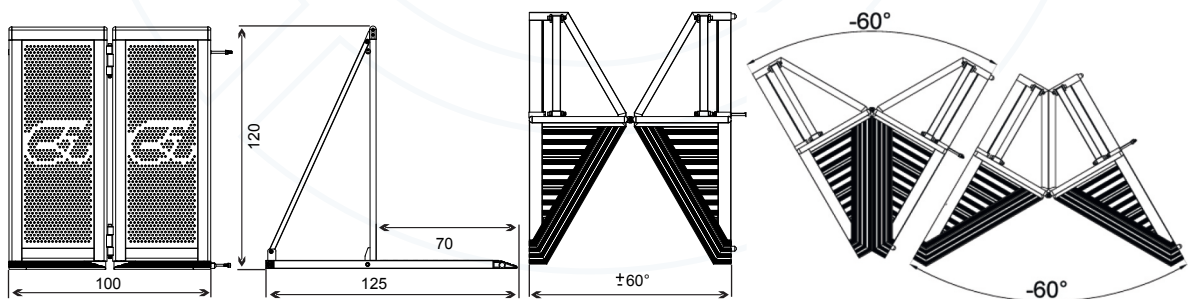

TECHNICAL DATA

Material	Aluminum alloy
Open Barrier dimensions	100 x 125 H 120 cm
Closed Barrier dimensions	100 x 125 H 10 cm
Corner	$+60^\circ$ or -60°
Weight	36 kg

Advantages

- **Fingers Save System**
- Extended anti skid footboard for a better stable
- Safe and comfortable solutions for both the audience and rescue personnel.

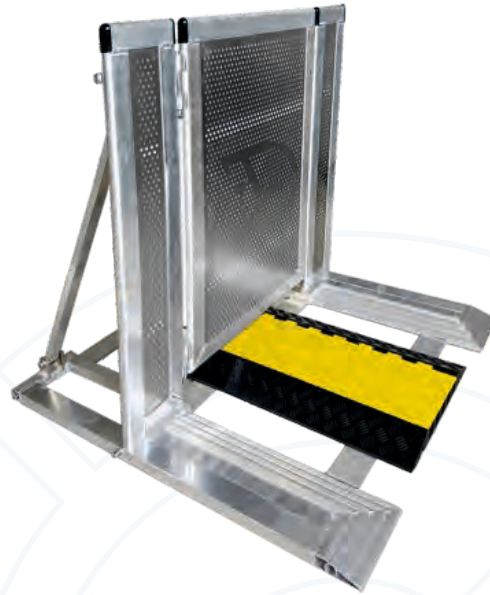

Gate access and cable module

Gate access modules, made of aluminum, are designed to accommodate the transit of cables, hoses and ducts. The gate leaves enough room in width and height to pass any type of standard cable ramp. The door facilitates an easy and fast opening for access of working technicians or security personnel.

The strength of Efesto's crowd barriers is Fingers Save system.

This safety is given from combination of edges rounded and a special self-centering upper connection.

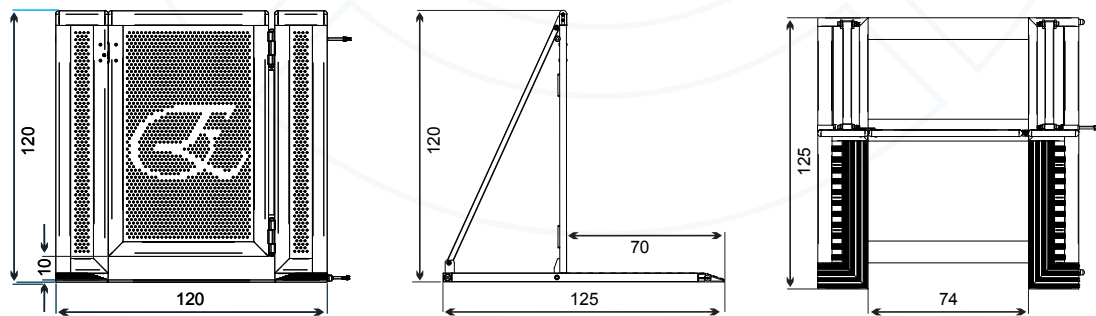

TECHNICAL DATA

Material	Aluminium alloy (Anticorodal)
Open Barrier dimensions	120 x 125 H 120 cm
Closed Barrier dimensions	120 x 125 H 10 cm
Gate width	70 cm
Weight	46 kg

Advantages

- **Fingers Save System**
- Extended anti skid footboard for a better stable
- Safe and comfortable solutions for both the audience and rescue personnel.



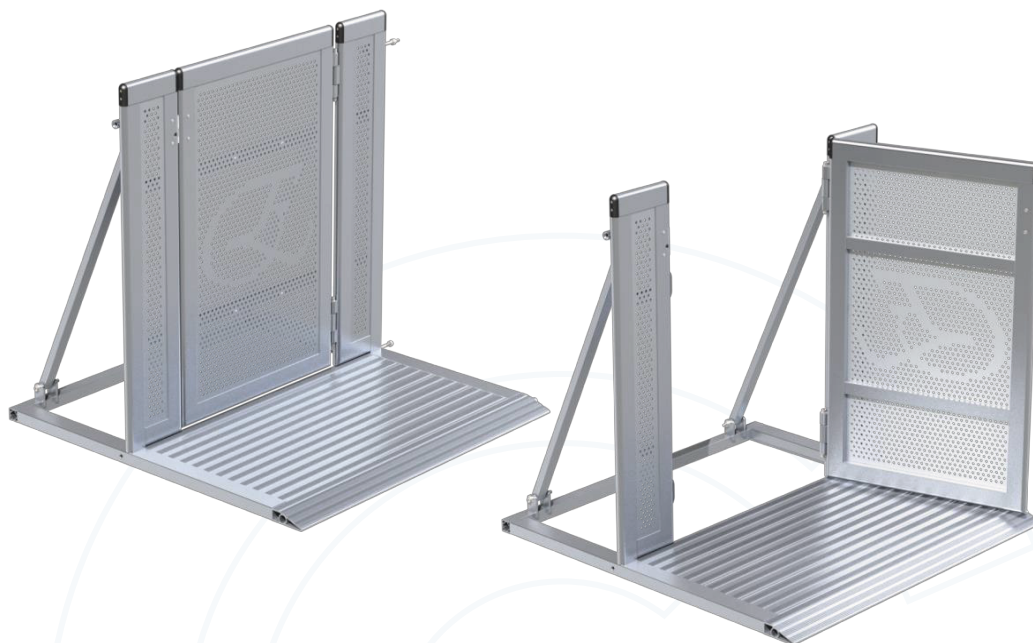

Gate access module

Gate access modules, made of aluminum, are designed for offering an easy and fast opening for access of working technicians or security personnel.

The strength of Efesto's crowd barriers is Fingers Save system.

This safety is given from combination of edges rounded and a special self-centering upper connection.

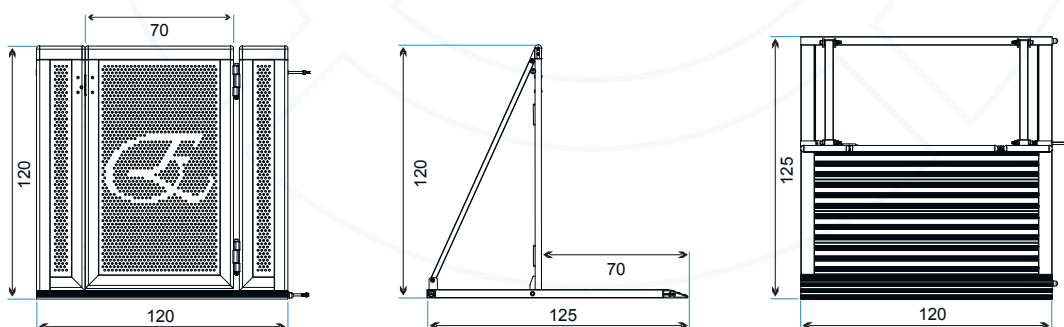

TECHNICAL DATA

Material	Aluminum alloy
Open Barrier dimensions	120 x 125 H 120 cm
Closed Barrier dimensions	120 x 125 H 10 cm
Gate width	70 cm
Weight	47 kg

Advantages

- **Fingers Save System**
- Extended anti skid footboard for a better stable
- Safe and comfortable solutions for both the audience and rescue personnel.



STAGE BARRIERS EMERGENCY GATE MODULE

Inventory - 2 pieces



Emergency gate module

Emergency Gate Module is an fast and comfortable access: two separate door gates provide a convenient entrance and/or exit point for your staff before, during and after the event (Gate access width - 180 cm). The **Emergency access barrier** can be used as regular barrier when audiences and spectators need to be held at a distance but also as a gateway to quick walk through when a bigger opening is needed.

The **anti skid - sloped deck** front and back allow a easier lifting of people with health issue over the barrier.

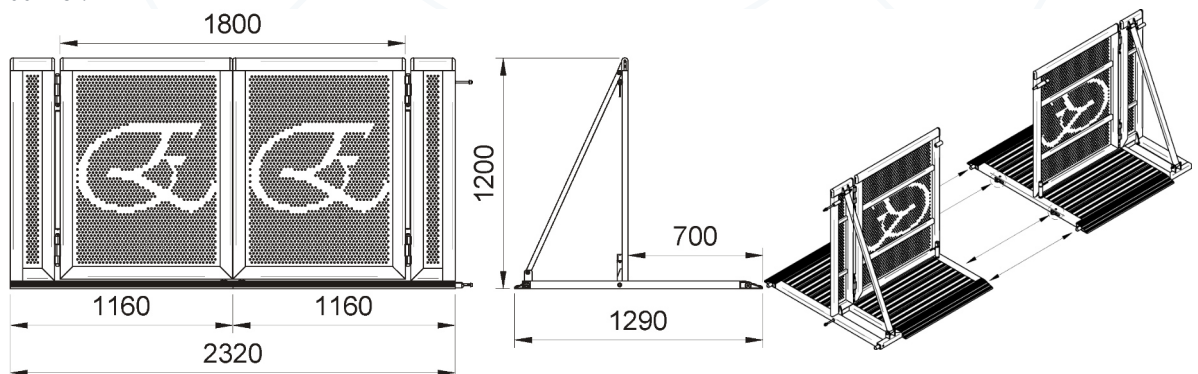

TECHNICAL DATA

Material	Aluminum alloy
Open Barrier dimensions	232 x 129 H 120 cm
Closed Barrier dimensions	116 x 129 H 20 cm
Gate width	180 cm
Weight	98 kg

Advantages

- **Fingers Save System**
- Gate access width: 180 cm
- Anti skid sloped deck front and back
- Extended anti skid footboard for a better stable
- Safe and comfortable solutions for both the audience and rescue personnel.



STAGE BARRIERS

EMERGENCY MEGA GATE MODULE

In Inventory **SOON**

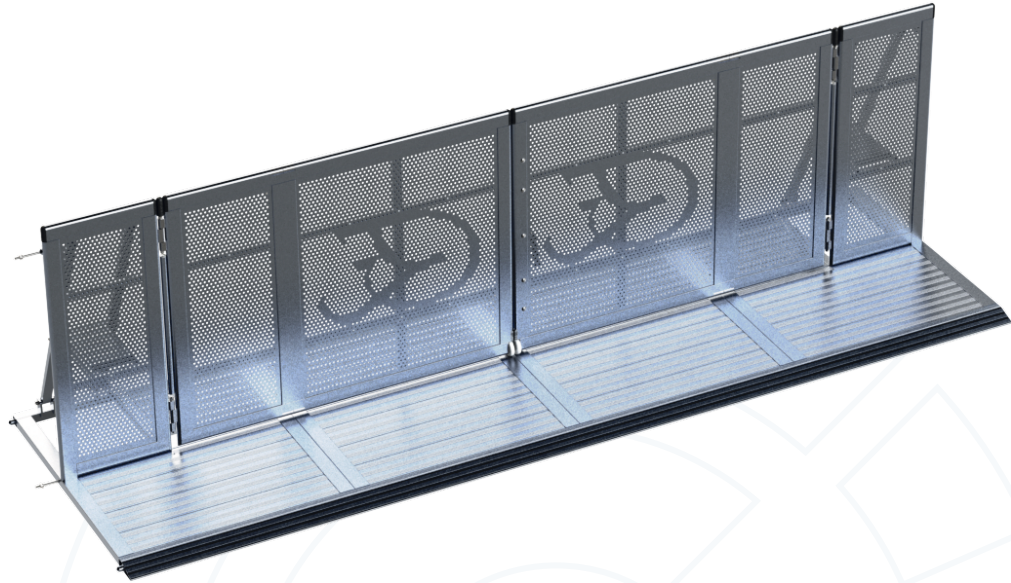

Emergency Mega gate module

Emergency Mega Gate Module is a fast and comfortable access: two separate door gates provide a convenient entrance and/or exit point for your staff and Emergency Cars, before, during and after the event (Gate access width - 300 cm).

The **Emergency access barrier** can be used as regular barrier when audiences and spectators need to be held at a distance but also as a gateway to quick walk through when a bigger opening is needed.

The **anti skid - sloped deck** front and back allow a easier lifting of people with health issue over the barrier.

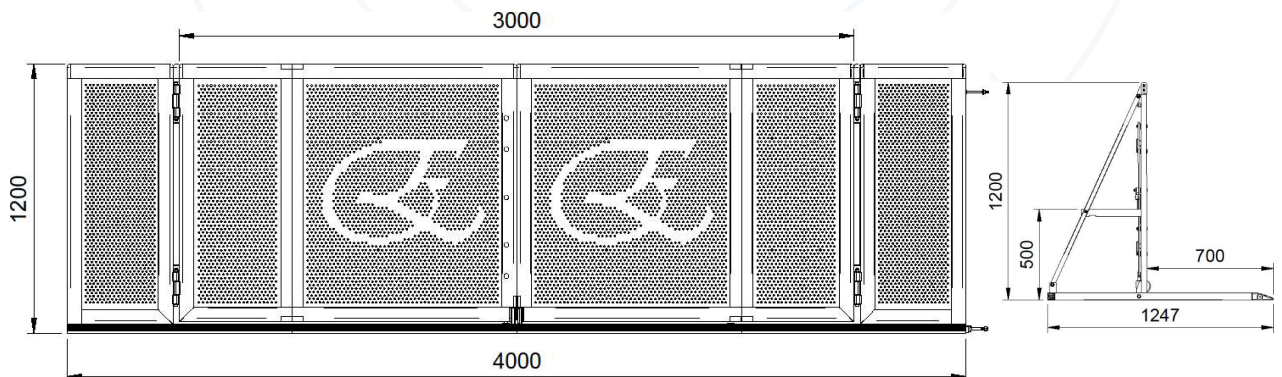

TECHNICAL DATA

Material	Aluminum alloy
Open Barrier dimensions	400 x 125 H 120 cm
Closed Barrier dimensions	100 x 125 H 20 cm
Gate access width	300 cm
Weight	170 kg

Advantages

- **Fingers Save System**
- Gate access width: 300 cm
- Anti skid sloped deck front and back
- Extended anti skid footboard for a better stable
- Safe and comfortable solutions for both the audience and rescue personnel.



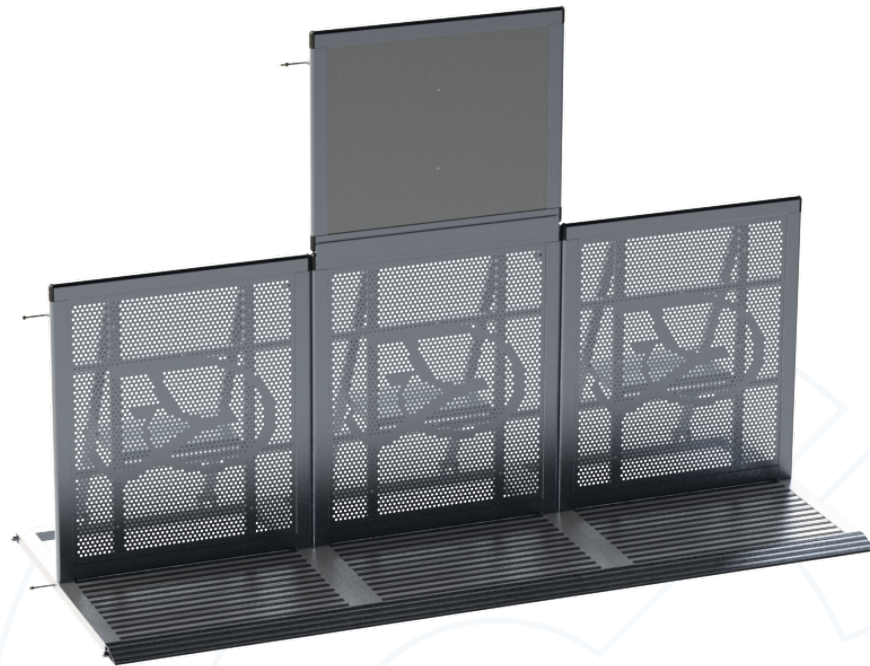

View Block Element

The **View Block Element** is suitable as an additional element for an opaque increase of barricade lines and are a good support for signage. By blocking the view, the **View Block Elements**, are ideal for keep the entrances / exits areas as free is possible, or for creating separate private areas for dedicated areas.

The elements can protect artists, security personnel, or crew members.

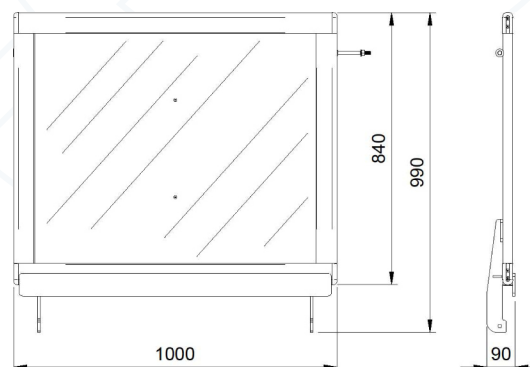

TECHNICAL DATA

Material	Aluminum alloy
Element dimensions	100 x 99 H 9 cm
Crowd Barrier + View Block Element total height	200 cm
Weight	12,5 kg

Advantages

- **Fingers Save System**
- Safe and comfortable solutions for both the audience and rescue personnel.



Merchandise Stand Module

Merchandise Stand Module (100x40 cm) it can transform the Standard Module into stable counters. Ideal for serving areas such as F&B (food and drinks), merchandise stands, sales counters, info point and more.

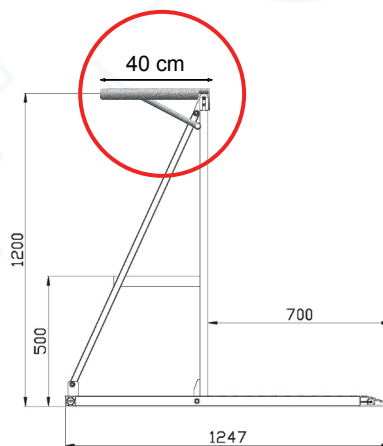

TECHNICAL DATA

Material	Aluminum alloy
Element dimensions	100 x 99 H 9 cm
Crowd Barrier + View Block Element total height	200 cm
Weight	12,5 kg

Advantages

- **Fingers Save System**
- Safe and comfortable solutions for both the audience and rescue personnel.





Dolly transport module

A aluminum dolly has been developed to hold 10 folded standard crowd barriers. Crowd barriers folded flat are easily stored and transported in the dolly. The dollies transport module can be stacked on top of each other to save space in storage.

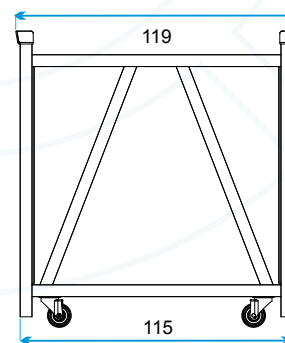
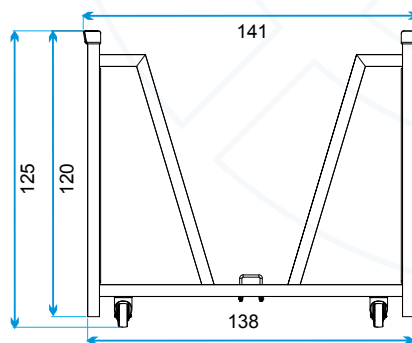

TECHNICAL DATA

Material	Aluminum alloy
Dolly dimensions	119 x 141 H 120 cm
Number of barriers	10 folded standard crowd barriers
Weight	45 kg

Advantages

- **Fingers Save System**
- Extended anti skid footboard for a better stable
- Safe and comfortable solutions for transport

HERE FOR YOU!

Emergency Exit

Venue

Entrance

Emergency Exit

EVENT SAFETY MANAGEMENT

E office@noaevent.ro T +40 728 303927 W www.crowdandsafety.ro

EVENT SAFETY MANAGEMENT